

Pulse Testing High Brightness LEDs Accurately Using the 2461 High Current SourceMeter® SMU Instrument

APPLICATION NOTE



KEITHLEY
A Tektronix Company

Tektronix®

APPLICATION NOTE

Visible high brightness light emitting diodes (HBLEDs) have gained a reputation for high efficiency and long lifetimes, which has led to their use in a growing list of applications, including automotive displays and exterior lights, backlighting for televisions and video monitors, street lights, outdoor signs, and interior lighting. Extensive research and development efforts by LED manufacturers have led to the creation of LEDs with higher luminous flux, longer lifetimes, greater chromaticity, and more lumens per watt, which has driven demand and encouraged an even wider array of applications. Accurate and cost-effective testing is critical to ensuring the reliability and quality of these devices.

Due to the high operating power of these devices, the semiconductor junction of the LED will tend to heat during testing (See **Figure 1.**) As the junction heats, the forward voltage will drop or the leakage current will increase during the constant voltage test. These effects can impact the accuracy of the test or, more importantly, potentially damage the device under test. Therefore, it is important to shorten each test time as much as possible without sacrificing measurement accuracy or stability.

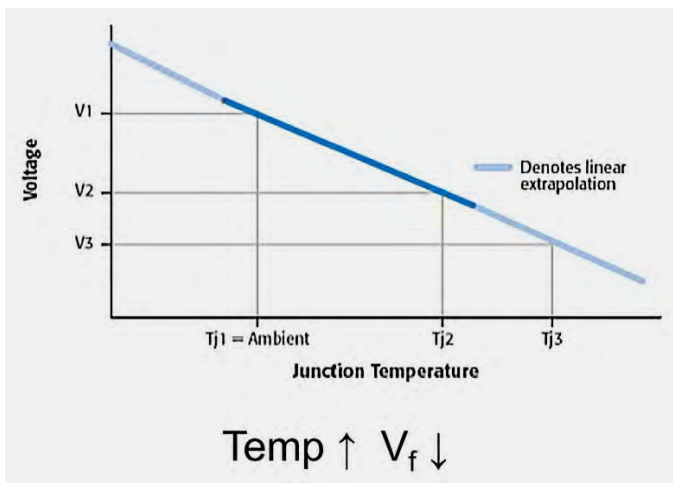

FIGURE 1. An HBLED's junction heats as current is sourced through it. An HBLED's forward voltage drops as its junction heats.

The 2461 SourceMeter SMU Instrument's built-in pulsing capabilities and fast A/D converter make shortening test times simple. The instrument is capable of pulsing at up to 10A, 100V with a minimum pulse width of 150 μ s. These features allow the 2461 to minimize self-heating and damage to HBLEDs and enable more reliable testing. The wide 1KW power envelope

and accurate timing of the 2461's pulses allow it to safely test very high power devices without fear of damage. The pulses can be configured directly on the front panel of the instrument or over a remote communication bus.

Figure 2 demonstrates two HBLED I-V sweeps performed with the 2461. The green curve shows the sweep performed using its built-in pulsing capabilities. The blue curve shows the same sweep performed using a traditional sweep without pulsing. The green pulsed curve exhibits no self-heating effects, but the blue curve exhibits self-heating and catastrophic failure. The device under test would have been untestable without the use of pulsing.

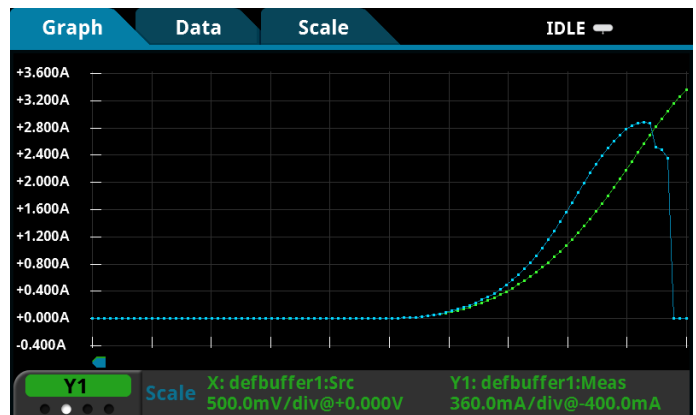

FIGURE 2. Two I-V sweeps run on the same HBLED. The green curve is a pulse I-V sweep. The blue curve is a traditional I-V sweep that led to overheating and

This application note provides information on typical HBLED tests and how to perform them using the pulse functionality of the 2461. Directions on how to set up the tests from the front panel are included with each example. The appendices include example TSP[®] Test Script Processor code for each example.

Making Connections to the LED

The LED is connected to the 2461 as shown in **Figure 3.** A four-wire connection is made to eliminate the effects of the lead resistance. When connecting the leads to the LED, the Force LO and Sense LO connections are made to the cathode terminal. The Force HI and Sense HI connections are made to the anode. Make the connections as close as possible to the cell to prevent the resistance of the LED's terminals from affecting the measurement accuracy.

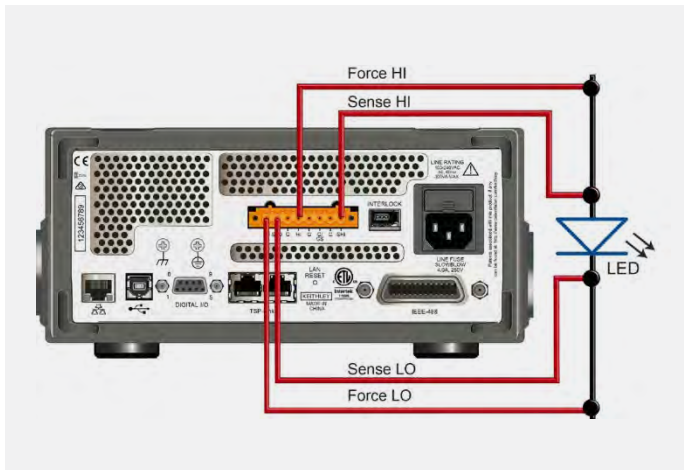
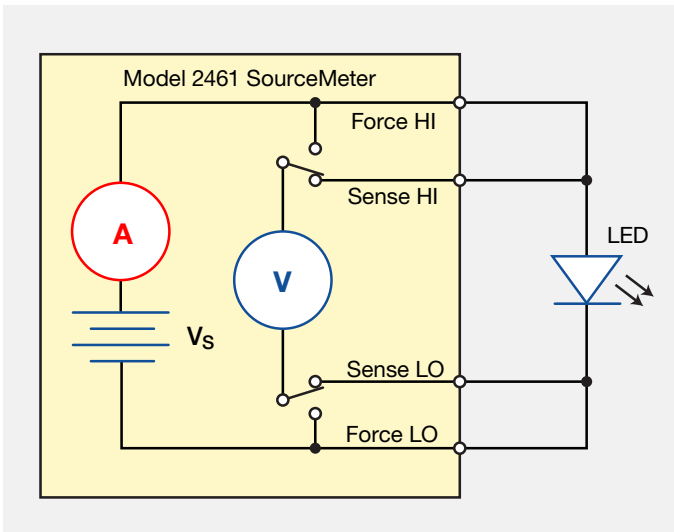

FIGURE 5. 2461 4-wire rear-panel connections to an LED.

The following figures show the physical connections for the front and rear panels. Figure 4 shows the front-panel connections. You can make these connections with four insulated banana cables that are rated to the maximum current (10 A) such as two sets of the Keithley 8608 High-Performance Clip Lead Set.

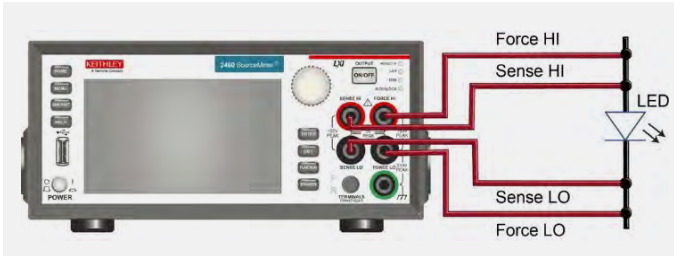

Figure 5 shows the rear-panel connections. You can make these connections with either the 2460-KIT Screw Terminal Connector Kit (included with the 2461) or a 2460-BAN Banana Test Leads/Adapter Cable with appropriate cabling.

Test Descriptions

The 2461 can easily be programmed to perform a pulse I-V curve test, pulsed forward voltage test (V_f), a pulsed leakage test (I_L) and a pulsed reverse breakdown test (V_R). This can be achieved from the front panel of the instrument or by sending TSP or SCPI commands to the instrument.

Some tests require sourcing a known current and measuring a voltage, while others require sourcing a voltage and measuring the resulting current. A SourceMeter® SMU instrument is ideal for these types of tests, because it can be configured to source voltages or currents and can also measure each of these signal types.

Pulsed I-V Curve

Testing LEDs typically involves both electrical and optical measurements. This application note focuses on electrical characterization. Figure 6 illustrates the electrical I-V curve of a typical diode. A complete test includes a multitude of voltage values versus current operating points during the R&D phase, but a limited sample of points is generally sufficient to probe for the figures of merit, especially during the product validation phase and production.

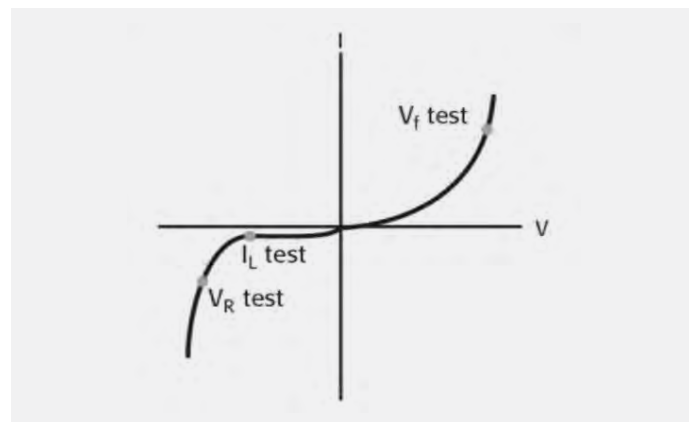

FIGURE 6. Typical HBLED DC I-V curve and test points for manufacturing tests (not to scale).

Performing the Test from the Front Panel

Description	Key Strokes
Reset instrument to default state	Menu key → Manage System → Reset
Set to source V and measure I	Home key → Function key → Source V Measure I
Configure measure settings	Menu key → Measure Settings → Sense Mode → 4-Wire Sense
	NPLCs → .01
	Auto Zero → Off
Configure pulse sweep parameters	Menu key → Source Pulse
	• Set Pulse Type to Pulse Sweep Points
	• Set all desired source and timing parameters
	• Scroll down and set Limit and Bias Limit
Execute I-V sweep	• Press Generate to create sweep
	Home key → Trigger key

Performing the Test from a Remote Interface

An example TSP script is included in Appendix A of this application note that demonstrates how to use the built-in pulsing capability of the 2461 to perform a pulsed I-V sweep. The test is set up to sweep from 0 to 4.15 V in 100, 1ms long pulses. When the test is executed, the I-V curve in **Figure 7** is displayed on the front panel of the instrument. **Figure 8** shows a sample pulse captured with the digitizing A/D converter to show the short pulse length and very tight timing of the 2461.

Test Results

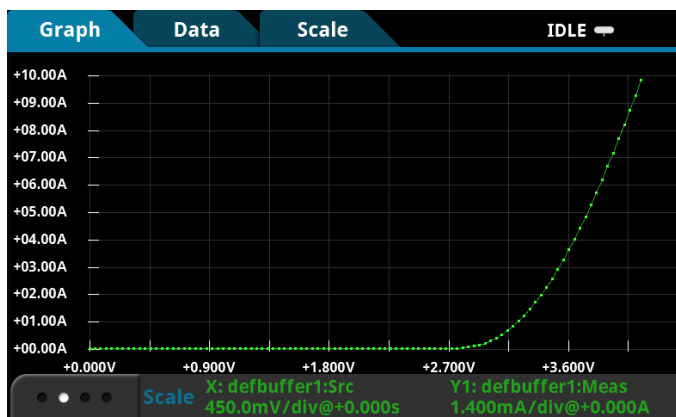

FIGURE 7. The resulting graph of a pulsed I-V sweep on the front panel of the 2461.

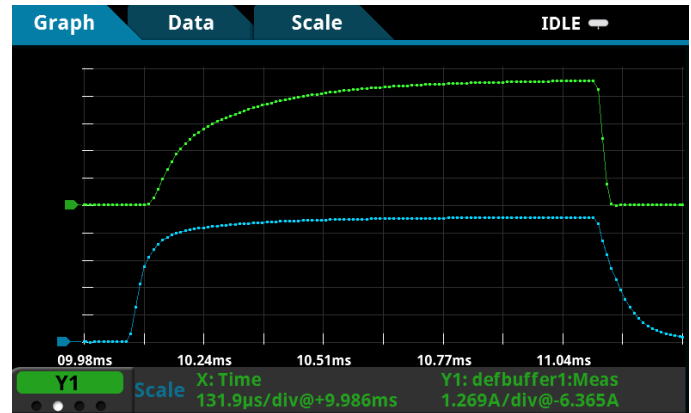

FIGURE 8. Using the 2461's digitizing A/D converter to show the V_f pulse response. The forced voltage waveform is shown in blue and the measured current waveform is shown in green.

Forward Voltage Test

The V_f test verifies the forward operating voltage of the visible LED. When a forward current is applied to the diode, it begins to conduct. During the initial low current source values, the voltage drop across the diode increases rapidly, but the slope begins to level off as drive currents increase. The diode normally operates in this region of relatively constant voltage. It is also quite useful to test the diode under these operating conditions. The forward voltage test (V_f) is performed by sourcing a known current and measuring the resulting voltage drop across the diode. Typical test currents range from tens of milliamps to amps, while the resulting voltage measurement is typically in the range of a few volts. The results of this test are typically used by engineers and designers, as the forward voltage is directly related to the chromaticity of the LED.

Forward current biasing is also used for optical tests, because electrical current flow is closely related to the amount of light emitted. Optical power measurements can be made by placing a photodiode or integrating sphere close to the device under test to capture the emitted photons. This light is then converted to a current, which can be measured by an ammeter or a SourceMeter SMU instrument.

In many test applications, the voltage and light output of the diode can be measured simultaneously using a fixed source current value. In addition, details such as spectral output can be obtained by using the same drive current value and a spectrometer.

Typical polarization times for the V_f test are from less than a few hundred microseconds to five milliseconds, and from 5 to 20 milliseconds for the I_L test. By using these short pulse test times, errors due to the junction heating are reduced. Also, the junction heating characteristics can be determined by performing a series of tests and only varying the test time.

Performing the Test from the Front Panel

Description	Key Strokes
Reset instrument to default state	Menu key → Manage System → Reset
Set to source V and measure I	Home key → Function key → Source I Measure V
Configure measure settings	Menu key → Measure Settings → Sense Mode → 4-Wire Sense NPLCs → .01 Auto Zero → Off
Configure pulse train parameters	Menu key → Source Pulse <ul style="list-style-type: none"> • Set Pulse Type to Pulse Train • Set all desired source and timing parameters • Scroll down and set Limit and Bias Limit • Press Generate to create sweep
Execute I-V sweep	Home key → Trigger key

Performing the Test from a Remote Interface

An example TSP script is included in Appendix B of this application note that demonstrates how to use the built-in pulsing capability of the 2461 to perform a pulse forward voltage test. The example script performs five 5ms current pulses and measures the forward voltage at the end of each pulse. **Figure 9** shows the reading table containing the five forward voltage measurements.



FIGURE 9. The results of five repeated forward voltage tests on a high brightness LED.

Reverse Leakage Test

Normally, moderate voltage levels (volts to tens of volts) are used to measure a leakage current (I_L). The leakage current test measures the low-level current that leaks across the LED when a reverse voltage less than breakdown is applied. It is a common practice for leakage measurements, and more generally for isolation measurements, to make sure that a certain threshold is not exceeded, especially in production. There are two reasons for this. First, low current measurements require longer settling times, so they take longer to complete. Second, environmental interference and electrical noise exert greater influence on low level signals, so extra care in shielding is required. However, this extra shielding may complicate the test fixture and may interfere with auto-mated handlers.

To perform a reverse leakage test, set the instrument to source a negative voltage pulse and measure the resulting leakage current using the pulse train sweep type.

Performing the Test from the Front Panel

Description	Key Strokes
Reset instrument to default state	Menu key → Manage System → Reset
Set to source V and measure I	Home key → Function key → Source V Measure I
Configure measure settings	Menu key → Measure Settings → Sense Mode → 4-Wire Sense NPLCs → .01 Auto Zero → Off
Configure pulse train parameters	Menu key → Source Pulse <ul style="list-style-type: none"> • Set Pulse Type to Pulse Train • Set all desired source and timing parameters • Scroll down and set Limit and Bias Limit • Press Generate to create sweep
Execute I-V sweep	Home key → Trigger key

Performing the Test from a Remote Interface

An example TSP script is included in Appendix C of this application note that demonstrates how to use the built-in pulsing capability of the 2461 to perform a pulsed reverse leakage test. The example script performs five 20ms negative voltage pulses and measures the leakage current at the end of each pulse. **Figure 10** shows the reading table containing the five leakage current measurements.

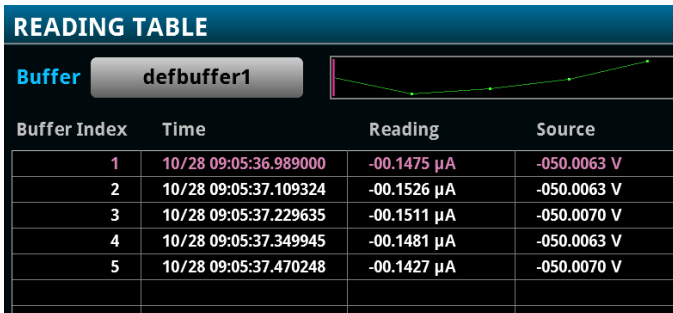

FIGURE 10. The results of five repeated reverse leakage tests on a high

Reverse Breakdown Test

Applying a negative bias current to the LED will allow probing for the so-called reverse breakdown voltage (V_R). The test current should be set to a level where the measured voltage value no longer increases significantly when the current is increased slightly more. At levels higher than this voltage, large increases in reverse bias current result in insignificant changes in reverse voltage. The specification for this parameter is usually a minimum value. The test is performed by sourcing a low-level reverse bias current for a specified time, then measuring the voltage drop across the LED. The measurement result is typically in the range of tens of volts.

Performing the Test from the Front Panel

Description	Key Strokes
Reset instrument to default state	Menu key \rightarrow Manage System \rightarrow Reset
Set to source V and measure I	Home key \rightarrow Function key \rightarrow Source I Measure V
Configure measure settings	Menu key \rightarrow Measure Settings \rightarrow Sense Mode \rightarrow 4-Wire Sense NPLCs \rightarrow .01 Auto Zero \rightarrow Off
Configure pulse train parameters	Menu key \rightarrow Source Pulse <ul style="list-style-type: none"> • Set Pulse Type to Pulse Train Points • Set all desired source and timing parameters • Scroll down and set Limit and Bias Limit • Press Generate to create sweep
Execute I-V sweep	Home key \rightarrow Trigger key

Performing the Test from a Remote Interface

An example TSP script is included in Appendix D of this application note that demonstrates how to use the built-in pulsing capability of the 2461 to perform a pulsed reverse breakdown voltage test. The example script performs five 15ms negative current pulses and measures the breakdown voltage at the end of each pulse. **Figure 11** shows the reading table containing the five breakdown voltage measurements.

Test Results

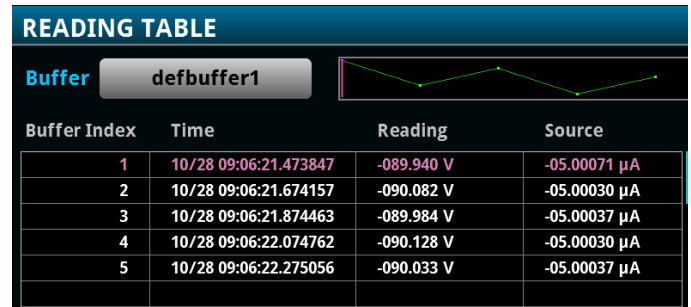

FIGURE 11: The results of five repeated reverse breakdown tests on a high brightness LED.

Generating, Plotting, and Saving I-V Sweeps Using the User Interface in Three Easy Steps

The I-V sweep of an HBLED can be accomplished using the 2461 either from the front panel or over the bus. Just a few key strokes are needed to generate, graph, and save the data to a USB drive. Here are the three easy steps to generate and graph a voltage sweep and then save the data to a USB drive.

Step 1. Creating and Executing an I-V Sweep from the Front Panel Graphical User Interface

Description	Key Strokes
Reset instrument to default state	Menu key \rightarrow Manage System \rightarrow Reset
Set to source V and measure I	Home key \rightarrow Function key \rightarrow Source V Measure I
Set to four-wire sense	Menu key \rightarrow Measure Settings \rightarrow Sense Mode \rightarrow 4-Wire Sense
Configure sweep parameters	Menu key \rightarrow Source Sweep <ul style="list-style-type: none"> • Set desired Start, Stop, and Step V • Scroll down and set Source Limit • Press Generate to create sweep
Execute I-V sweep	Home key \rightarrow Trigger key

Step 2. Viewing the Graph

To view the data graphically, press the MENU key and then the Graph button. The graph of the I-V sweep will automatically be displayed. To repeat the test, just press the TRIGGER key.

Figure 12 shows the I-V curve of an HBLED generated by the 2461. **Figure 13** illustrates how bright an HBLED can get at the high levels of current.

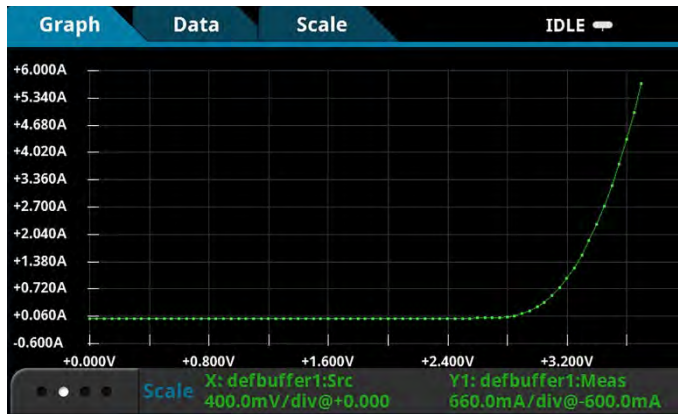

FIGURE 12: HBLED I-V sweep generated on the graph screen of the 2461.



FIGURE 13: HBLED illuminated at 4.1 volts and 4.8 amps.

Step 2. Viewing the Graph

To view the data graphically, press the MENU key and then the Graph button. The graph of the I-V sweep will automatically be displayed. To repeat the test, just press the TRIGGER key.

Figure 12 shows the I-V curve of an HBLED generated by the 2461. **Figure 13** illustrates how bright an HBLED can get at the high levels of current.

Step 3. Saving the Data to a USB Drive

To save the I-V data to a USB drive, just insert a USB drive, press the MENU key, select Reading Buffers, and then press SAVE TO USB (see **Figure 14**). Enter the name of the file. The data will be saved in a .csv format so it can later be downloaded to a spreadsheet and analyzed.



FIGURE 14: Saving data to a USB drive.

Screening for the Thyristor Effect

A fast-sampling A/D converter is also included in the 2461. The digitizing A/D enables the 2461 to capture voltage and current waveforms simultaneously at 1 million samples per second. An entire pulse waveform can be digitized and viewed on the front panel of the instrument or saved to a USB flash drive and viewed on a computer. This captured waveform can be used to view the pulse response of the HBLED under test and to screen for thyristor effects in manufacturing.

Appendix A

```

smu.reset()
--Set up the pulse parameters (user-specified)
configListName = "myPulseSweep"
bias_level = 0
start = 0
stop = 4.15
points = 100
pulse_width = 1e-3
MeasureEnable = smu.ON
bufferName = defbuffer1
delay = 0
offTime = 19e-3
count = 1
xBiasLimit = 1
xPulseLimit = 10
failAbort = smu.ON
dual = smu.OFF

--Set the source to output voltage.
smu.source.func = smu.FUNC_DC_VOLTAGE
smu.source.readback = smu.OFF

--Set up the measure functions.
smu.measure.func = smu.FUNC_DC_CURRENT
smu.measure.sense = smu.SENSE_4WIRE
smu.measure.nplc = .01
smu.measure.autozero.enable = smu.OFF

--Send the pulse sweep command to set up the trigger model
and config lists.
smu.source.pulsesweeplinear(configListName, bias_level, start,
stop, points, pulse_width, MeasureEnable, bufferName, delay,
offTime, count, xBiasLimit, xPulseLimit, failAbort, dual)

--Start the trigger model
waitcomplete()
trigger.model.initiate()

```

Appendix B

```

smu.reset()
--Set up the pulse parameters (user-specified)
configListName = "myPulses"
bias_level = 0
pulse_level = 1
pulse_width = 5e-3
count = 5
MeasureEnable = smu.ON
bufferName = defbuffer1
delay = 0
offTime = 50e-3
xBiasLimit = 7
xPulseLimit = 7
failAbort = smu.ON

--Set the source to output current
smu.source.func = smu.FUNC_DC_CURRENT
smu.source.readback = smu.ON

--Set up the measure functions.
smu.measure.func = smu.FUNC_DC_VOLTAGE
smu.measure.autozero.enable = smu.OFF
smu.measure.nplc = .01
smu.measure.sense = smu.SENSE_4WIRE

--Send the pulse train command to set up the trigger model
and config lists.
smu.source.pulsetrain(configListName, bias_level, pulse_level,
pulse_width, count, MeasureEnable, bufferName, delay,
offTime, xBiasLimit, xPulseLimit, failAbort)

--Start the trigger model
waitcomplete()
trigger.model.initiate()

```

Appendix C

```
smu.reset()
--Set up the pulse parameters (user-specified)
configListName = "myPulses"
bias_level = 0
pulse_level = -50
pulse_width = 20e-3
count = 5
MeasureEnable = smu.ON
bufferName = defbuffer1
delay = 0
offTime = 50e-3
xBiasLimit = 10e-6
xPulseLimit = 10e-6
failAbort = smu.ON
```

--Set the source to output current

```
smu.source.func = smu.FUNC_DC_VOLTAGE
smu.source.readback = smu.ON
```

--Set up the measure functions.

```
smu.measure.func = smu.FUNC_DC_CURRENT
smu.measure.autozero.enable = smu.OFF
smu.measure.nplc = .01
smu.measure.sense = smu.SENSE_4WIRE
```

--Send the pulse train command to set up the trigger model and config lists.

```
smu.source.pulsetrain(configListName, bias_level, pulse_level,
pulse_width, count, MeasureEnable, bufferName, delay,
offTime, xBiasLimit, xPulseLimit, failAbort)
```

--Start the trigger model

```
waitcomplete()
trigger.model.initiate()
```

Appendix D

```
smu.reset()
--Set up the pulse parameters (user-specified)
configListName = "myPulses"
bias_level = 0
pulse_level = -5e-6
pulse_width = 15e-3
count = 5
MeasureEnable = smu.ON
bufferName = defbuffer1
delay = 0
offTime = 100e-3
xBiasLimit = 100
xPulseLimit = 100
failAbort = smu.ON
```

--Set the source to output current

```
smu.source.func = smu.FUNC_DC_CURRENT
smu.source.readback = smu.ON
```

--Set up the measure functions.

```
smu.measure.func = smu.FUNC_DC_VOLTAGE
smu.measure.autozero.enable = smu.OFF
smu.measure.nplc = .01
smu.measure.sense = smu.SENSE_4WIRE
```

--Send the pulse train command to set up the trigger model and config lists.

```
smu.source.pulsetrain(configListName, bias_level, pulse_level,
pulse_width, count, MeasureEnable, bufferName, delay,
offTime, xBiasLimit, xPulseLimit, failAbort)
```

--Start the trigger model

```
waitcomplete()
trigger.model.initiate()
```

Contact Information:

Australia 1 800 709 465
Austria 00800 2255 4835
Balkans, Israel, South Africa and other ISE Countries +41 52 675 3777
Belgium 00800 2255 4835
Brazil +55 (11) 3759 7627
Canada 1 800 833 9200
Central East Europe / Baltics +41 52 675 3777
Central Europe / Greece +41 52 675 3777
Denmark +45 80 88 1401
Finland +41 52 675 3777
France 00800 2255 4835
Germany 00800 2255 4835
Hong Kong 400 820 5835
India 000 800 650 1835
Indonesia 007 803 601 5249
Italy 00800 2255 4835
Japan 81 (3) 6714 3010
Luxembourg +41 52 675 3777
Malaysia 1 800 22 55835
Mexico, Central/South America and Caribbean 52 (55) 56 04 50 90
Middle East, Asia, and North Africa +41 52 675 3777
The Netherlands 00800 2255 4835
New Zealand 0800 800 238
Norway 800 16098
People's Republic of China 400 820 5835
Philippines 1 800 1601 0077
Poland +41 52 675 3777
Portugal 80 08 12370
Republic of Korea +82 2 6917 5000
Russia / CIS +7 (495) 6647564
Singapore 800 6011 473
South Africa +41 52 675 3777
Spain 00800 2255 4835
Sweden 00800 2255 4835
Switzerland 00800 2255 4835
Taiwan 886 (2) 2656 6688
Thailand 1 800 011 931
United Kingdom / Ireland 00800 2255 4835
USA 1 800 833 9200
Vietnam 12060128

Rev. 020916

For More Information:



Leading the way in test and measurement

Vicom Australia

1064 Centre Rd
Oakleigh South Vic
3167 Australia 1300
360 251
info@vicom.com.au
www.vicom.com.au

Vicom New Zealand

Grd Floor, 60 Grafton Road
Auckland 1010
New Zealand
+64 9 379 4596
info@vicom.co.nz
www.vicom.co.nz

Find more valuable resources at TEK.COM

Copyright © Tektronix. All rights reserved. Tektronix products are covered by U.S. and foreign patents, issued and pending. Information in this publication supersedes that in all previously published material. Specification and price change privileges reserved. TEKTRONIX and TEK are registered trademarks of Tektronix, Inc. All other trade names referenced are the service marks, trademarks or registered trademarks of their respective companies.

02.22.16 AH 1KW-60351-1

